

Quick Specs

Max. Output at Crankshaft	110 MHP (80.9 kW) /3200 RPM
Total Displacement	2 ltr / 122 cu in
Configuration	4-stroke, vertical, water-cooled
Cylinders	4
Engine Weight (Bobtail)	229 kg / 505 lbs

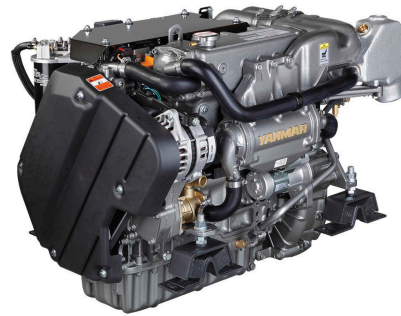

Legendary Reliability. Better Performance.

YANMAR engines are well known as some of the longest lasting and most reliable on the market. Thanks to the use of common rail technology, our new line of Tier 3 compliant engines now offer even better performance with higher torque, less noise, little to no smoke and increased fuel economy. Our engines are simply the best power package available for new vessels and re-power applications.

4JH110 Common Rail

New common rail design lowers emissions level.

Belt safety guard provides complete protection from belts and moving components.

High quality two layer paint protects surfaces from rust.



Common Rail Technology

New common rail technology allows for more precise fuel injection and smoother, quieter and cleaner operation.



Same Compact Size and Control Hookup

The new line of JH common rail engines has the same foot print as previous models for easy replacement of new and existing applications.



12V - 125A Alternator

The 12V - 125A Alternator allows for higher output and more power at a lower RPM.



More Information and NMEA 2000® Protocol

The engine control unit (ECU) allows for access to more information, including engine operation and fuel consumption.

ACCESSORIES

Standard Package

- Set of flexible engine mounts
- Exhaust mixing elbow [L-type]
- V-belt safety cover
- Fresh water expansion tank
- Alternator 12V - 125A
- Operation manual
- B25-panel
- Sensors for instrument panel
- Engine Topcover for protection

Optional

- Second alternator 12V - 125A or 24V - 60A
- High-riser mixing elbow [instead of L-elbow]
- Extension wire harness [3m, 5m, 10m]
- Hot water kit with cocks
- Second station harness and panel
- C35-panel
- Oil pressure sensor for C35-panel
- Extension saildrive leg [75 mm]
- NMEA 2000 convertor for Engine monitory system
- Emergency stop switch
- Seawaterpump front mounted

NOTE: All data subject to change without notice. Text and illustrations are not binding.



4JH110

specifications

Configuration	4-stroke, vertical, water-cooled diesel engine
Maximum output at crankshaft	*80.9 kW@3200 rpm (110 mhp@3200 rpm)
Combustion System	Direct injection with common rail system
Displacement	2.0 L (122 cu in)
Bore x stroke	84 mm x 90 mm (3.31 in x 3.54 in)
Aspiration	Turbocharged with intercooler
Alternator	12V - 125A
Cooling system	Fresh water cooling by centrifugal water pump and rubber impeller sea water pump
Direction of rotation (crankshaft)	Counter clockwise viewed from flywheel side
Dry weight without gear	229 kg (505 lbs)
Environmental Certification	Meets comprehensive emissions regulations in US: EPA Tier 3 EU: RCD/BSO II/EMC
Engine mounting	Rubber type flexible mounting

NOTE: Fuel condition: Density at 15°C = 0.84 g/cm³; 1kW = 1.3596 mhp = 1.3410 HP
 * Fuel temperature 40°C at the inlet of the fuel injection pump (ISO 8665)
 Technical data is according to ISO 8665 / 3046

PERFORMANCE CURVES

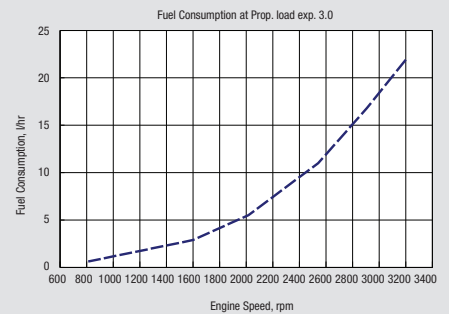
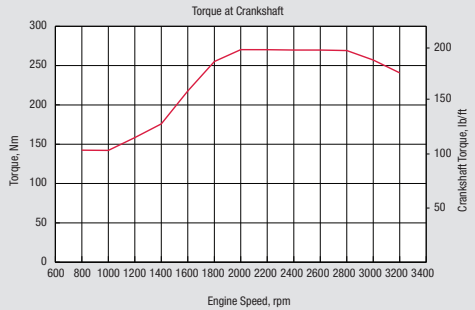
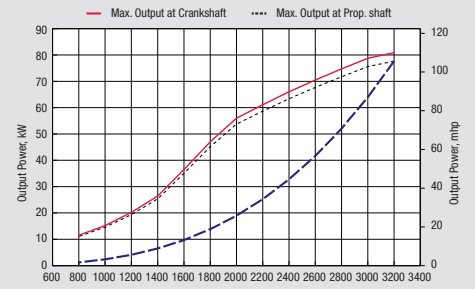

Rear View

Right Side View

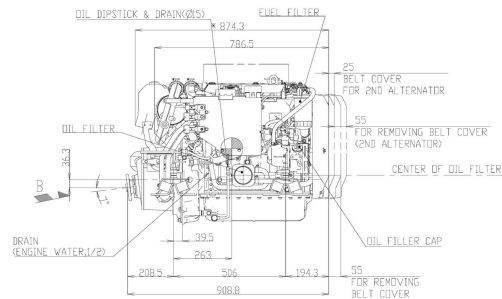
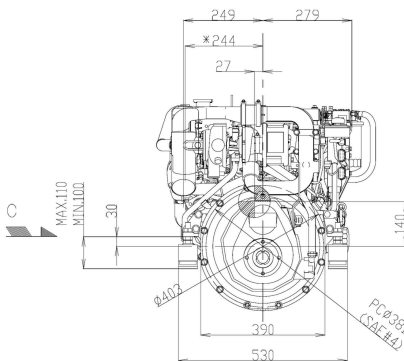

4JH110 with KM4A2 Marine Gear

Marine Gears/Drive

Model	KMH4A (down angle: 8°)	ZF25A (down angle: 8°)	KM4A2 (down angle: 7°)	ZF30M
Type	Hydraulic, multi-disc clutch	Hydraulic, multi-disc clutch	Mechanical cone clutch	Mechanical multi-disc
Dry Weight	71 lbs (32 kg)	66 lbs (30 kg)	73 lbs (33 kg)	61 lbs (28 kg)
Reduction Ratio (fwd/asn)	2.04/2.04 2.45/2.45	1.93/1.93 2.48/2.48	1.47/1.47 2.14/2.14 2.63/2.63	2.15/2.64 2.70/2.64
Propeller Speed (fwd/asn)	1569/1569 1306/1306	1658/1658 1290/1290	2177/2175 1495/1494 1217/1216	1488/1212 1185/1212
Direction of rotation (propeller shaft-fwd)	Clockwise & Counterclockwise viewed from stern	Clockwise & Counterclockwise viewed from stern	Clockwise & Counterclockwise viewed from stern	Clockwise viewed from stern
Dry weight engine & gear/drive	564.4 lbs (256 kg)	560 lbs (254 kg)	566.6 lbs (257 kg)	555.6 lbs (252 kg)
Length engine and gear/drive	35.7 in (907 mm)	35.6 in (905 mm)	35.8 in (909 mm)	36.4 in (925 mm)

Instrument Panels B and C

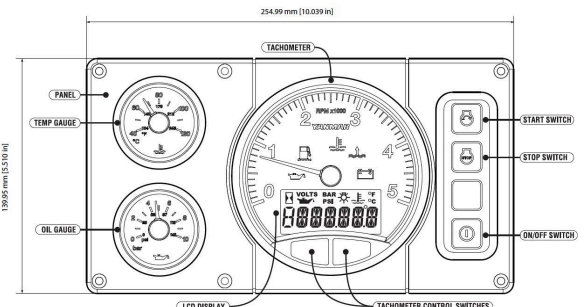
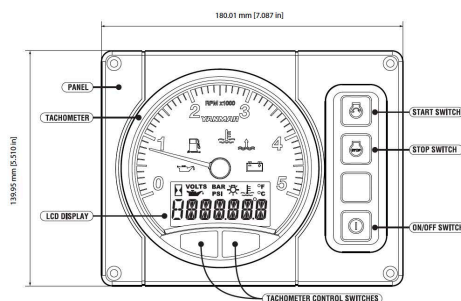

B25 STANDARD

C35 OPTIONAL