

DI13 085M. 478 kW (650 hp)

US Tier 3

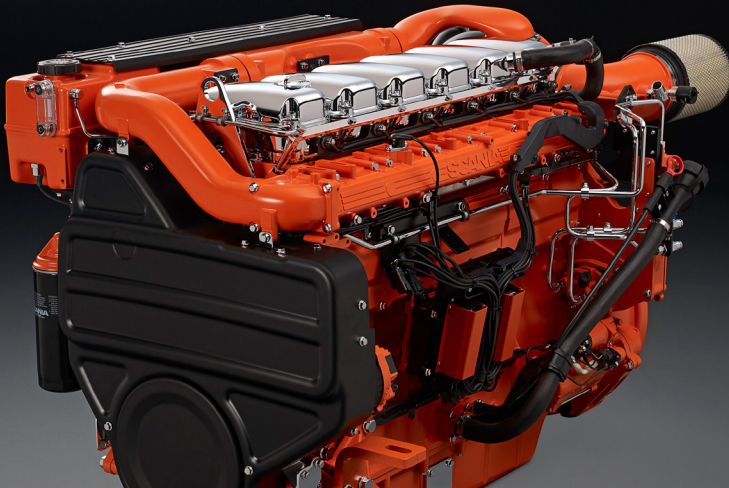

The marine engines from Scania are based on a robust design with a strength optimised cylinder block containing wet cylinder liners that can easily be exchanged. Individual cylinder heads with 4 valves per cylinder promotes reparability and fuel economy. The engines are type approved in all major classification societies.

The engine is equipped with a Scania developed Engine Management System, EMS, in order to ensure the control of all aspects related to engine performance. The injection system is based on electronically controlled unit injectors that gives low exhaust emissions with good fuel economy and a high torque already at low revs. The engine can be fitted with many accessories such as air cleaners, PTOs, transmissions and type approved instrumentation in order to suit a variety of installations.

	Rating	Engine speed (rpm)			
		1200	1500	1900	2300
Gross power, full load (kW)	Patrol craft long	237	379	454	478
Gross power, full load (hp, metric)		322	515	617	650
Gross power, propeller curve (kW)		94	164	296	478
Gross power, propeller curve (hp, metric)		128	223	403	650
Gross torque (Nm)		1886	2413	2282	1985
Spec fuel consumption. Full load (g/kWh)		201	205	197	217
Spec fuel consumption. 3/4 load (g/kWh)		195	198	203	212
Spec fuel consumption. 1/2 load (g/kWh)		195	200	209	217
Spec fuel consumption. Propeller curve (l/h)		22	40	73	124
Optimum fuel consumption (g/kWh)		194			
Heat rejection to coolant (kW)		168	259	293	377

Patrol craft long: Intended for intermittent use where rated power is available 1 h/6 h. Between full load operations engine rpm must be reduced at least 10% from max. obtained rpm. Accumulated total service time max. 2000 h/year.

Standard equipment

- Scania Engine Management System, EMS
- Unit injectors, PDE
- Turbocharger
- Fuel pre-filter with water separator
- Fuel filter
- Oil filter, full flow
- Centrifugal oil cleaner
- Oil cooler, integrated in block
- Oil filler, in engine block
- Oil dipstick, in block
- Starter, 2-pole 7.0 kW
- Alternator, 2-pole 100A
- Flywheel SAE 14
- Silumin flywheel housing, SAE 1 flange
- Front-mounted engine brackets
- Protection covers
- Closed crankcase ventilation
- Operator's manual

Engines with heat exchanger:

- Sea water pump
- Heat exchanger with expansion tank

Optional equipment

- Hydraulic pump
- Side-mounted PTO
- Front-mounted PTO
- Exhaust connections
- Electrical base system
- Control and instrument panels
- Accelerator position sensor
- Engine heater
- Power pack engine bracket
- Stiff rubber suspension
- Air cleaner
- Studs in flywheel housing
- Reversible fuel filter
- Low coolant level reaction
- Variable idle speed setting
- Low and extra low oil sump
- Long oil dipstick
- Oil level sensor
- Bilge pump

This specification may be revised without notice.

DI13 085M. 478 kW (650 hp)

US Tier 3

Engine description

No of cylinders	6 in-line
Working principle	4-stroke
Firing order	1 - 5 - 3 - 6 - 2 - 4
Displacement	12.7 litres
Bore x stroke	130 x 160 mm
Compression ratio	17.3:1
Weight (excl oil and coolant)	1285 kg (Engine with heat exchanger) 1180 kg (Engine with keel cooling)
Piston speed at 1500 rpm	8.0 m/s
Piston speed at 1800 rpm	9.6 m/s
Camshaft	High position alloy steel
Pistons	Steel pistons
Connection rods	I-section press forgings of alloy steel
Crankshaft	Alloy steel with hardened and polished bearing surfaces
Oil capacity	28-34 dm ³ (standard oil sump)
Electrical system	2-pole 24V

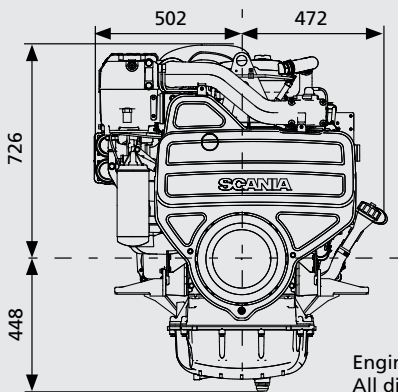
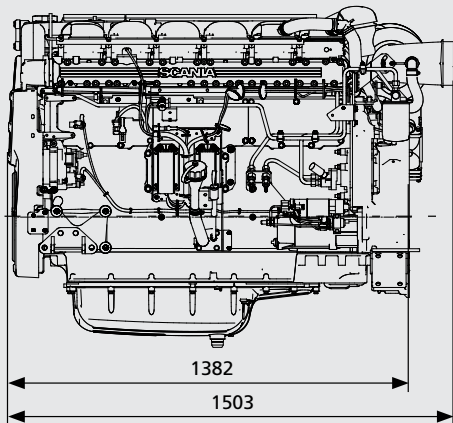

Engine with heat exchanger
All dimensions in mm

Output

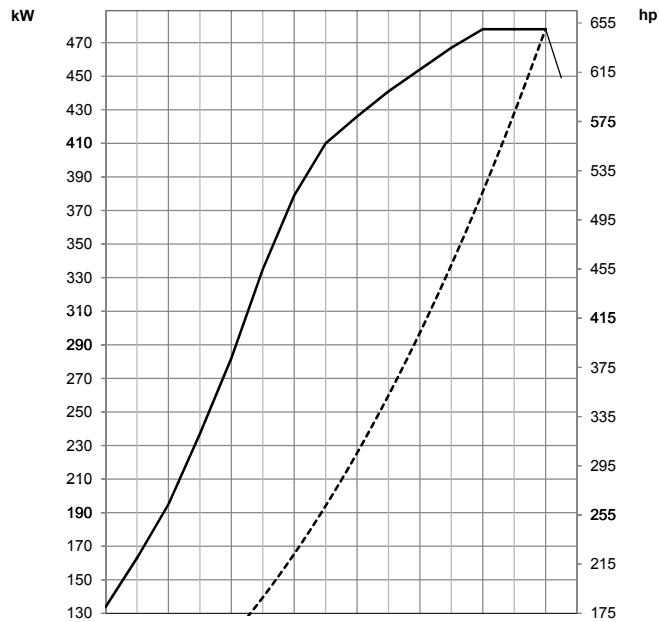

Torque

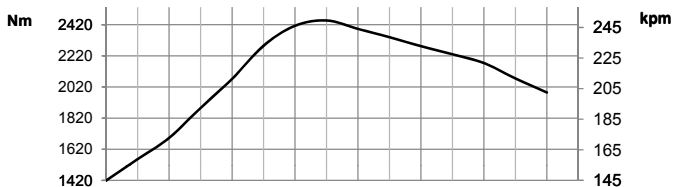

Spec fuel consumption

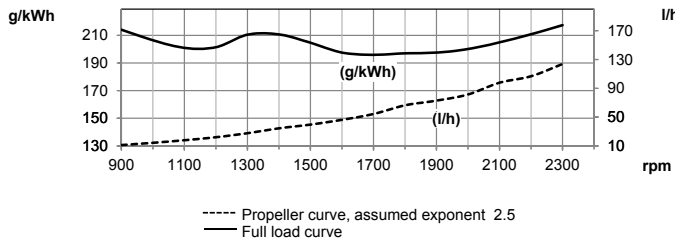

Test conditions Air temperature +25°C. Barometric pressure 100 kPa (750 mmHg). Humidity 30%. Diesel fuel acc. to ECE R 24 Annex 6. Density of fuel 0.840 kg/dm³. Viscosity of fuel 3.0 cSt at 40°C. Energy value 42700 kJ/kg. Power test code ISO 3046. Power and fuel values +/-3%.



SCANIA

SE 151 87 Södertälje, Sweden
Telephone +46 8 553 810 00
Telefax +46 8 553 829 93
www.scania.com
engines@scania.com