



4JH57 Common Rail Series

Configuration	4-stroke, vertical, water-cooled diesel engine	
Maximum output at crankshaft	*41.9 kW@3000 rpm	[57 mhp@3000 rpm]
Displacement	2.19 ltr	[134 cu in]
Bore x stroke	88 mm x 90 mm	[3.46 in x 3.54 in]
Cylinders	4 in line	
Combustion system	Direct injection with common rail system	
Aspiration	Natural aspiration	
Starting system	Electric starting 12V - 1.4 kW	
Alternator	12V - 125A	
Cooling system	Fresh water cooling by centrifugal water pump and rubber impeller sea water pump	
Lubrication system	Enclosed, forced lubricating system	
Direction of rotation [crankshaft]	Counterclockwise viewed from flywheel side	
Dry weight without gear	220 kg	[485 lbs]
Environmental	EU: RCD (will comply RCD2 from 2016) BSO II	EMC
	US: EPA Tier 3	
Engine mounting	Rubber type flexible mounting	

NOTE:

Fuel condition: Density at 15°C = 0.84 g/cm³: 1 kW = 1.3596 mhp = 1.3410 HP

* Fuel temperature 40°C at the inlet of the fuel injection pump [ISO 8665: 2006]

Technical data is according to ISO 8665: 2006

DIMENSIONS

Rear view

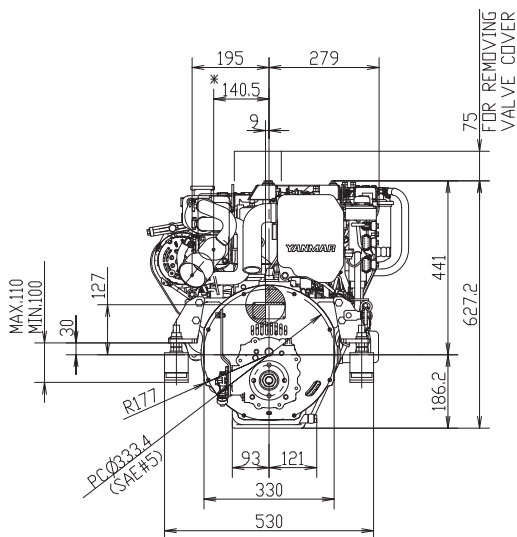

Right side view

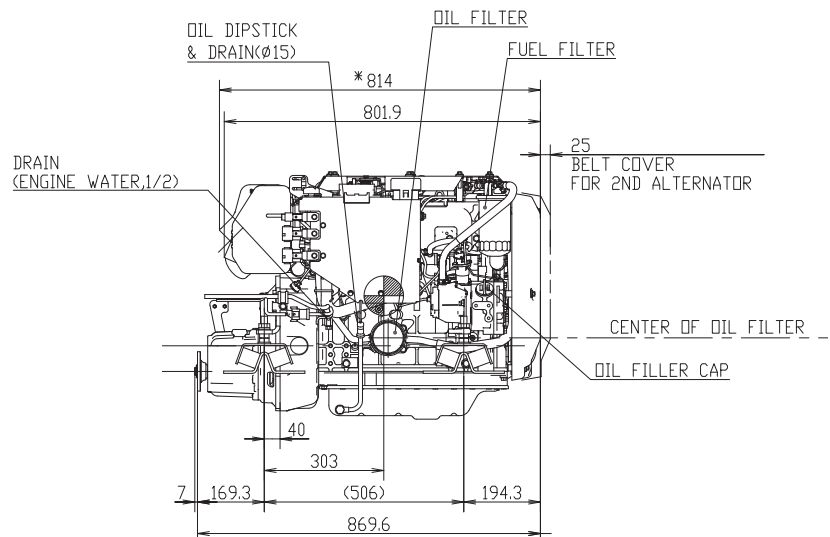

4JH57 with KM35P marine gear



PERFORMANCE CURVES

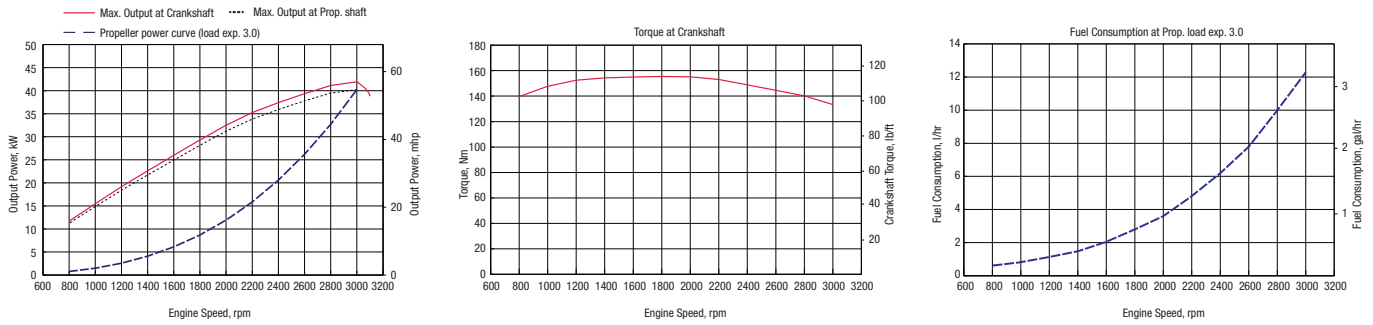

MARINE GEARS/DRIVE

Model	KM35P		KM35A2 [down angle: 7°]		KM4A1 [down angle: 7°]			ZF30M		Saildrive SD60	
Type	Mechanical cone clutch		Mechanical cone clutch		Mechanical cone clutch			Mechanical multi-disc		Mechanical wet type multi-disc	
Dry Weight	15 kg [33 lbs]		16 kg [35 lbs]		33 kg [73 lbs]			23 kg [51 lbs]		44 kg [97 lbs]	
Reduction Ratio [fwd/asn]	2.36/3.16 2.61/3.16		2.33/3.06 2.64/3.06		1.47/1.47 2.14 / 2.14 2.63/2.63			2.15/2.64 2.70/2.64		2.23/2.23 2.49/2.49	
Propeller speed [fwd/asn]	1271/949 1149/949		1288/980 1136/980		2041/2041 1402/1402 1141/1141			1395/1136 1111/1136		1345/1345 1205/1205	
Direction of rotation [propeller shaft - fwd]	Clockwise viewed from stern		Clockwise viewed from stern		Clockwise & counterclockwise viewed from stern			Clockwise viewed from stern		Clockwise & counterclockwise viewed from stern	
Dry weight - engine & gear	235 kg [518 lbs]		236 kg [520 lbs]		253 kg [558 lbs]			243 kg [536 lbs]		264 [582 lbs]	
Length engine and gear/drive	870 mm [34 in]		868 mm [34 in]		926 mm [36 in]			950 mm [37 in]		1113 mm [44 in]	

INSTRUMENT PANELS

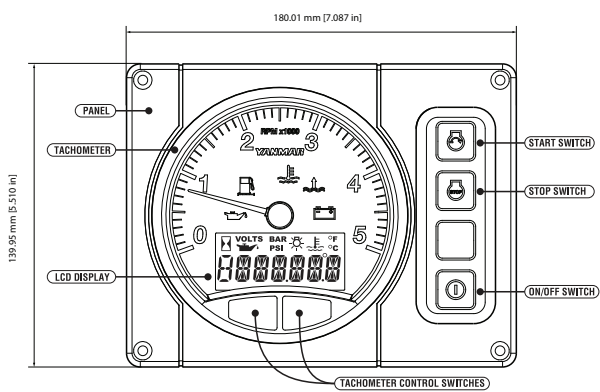

B25 STANDARD

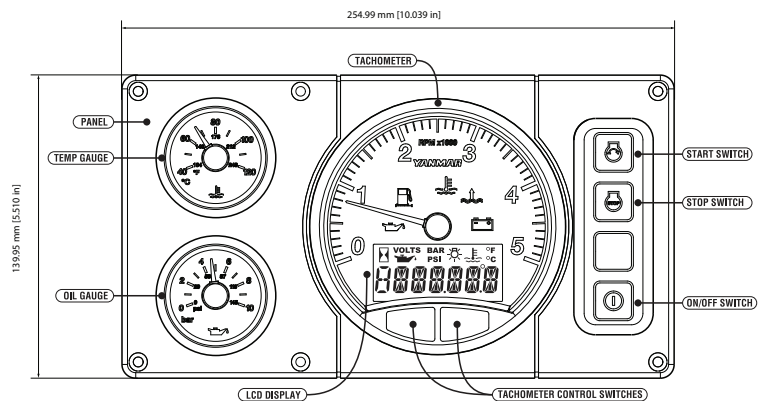

C35 OPTIONAL

ACCESSORIES

Standard Package

- Set of flexible engine mounts
- Exhaust mixing elbow [L-type]
- V-belt safety cover
- Fresh water expansion tank
- Alternator 12V - 125A
- Operation manual
- B25-panel
- Sensors for instrument panel
- Seawaterpump front mounted
- Engine Topcover for protection

Optional

- Second alternator 12V - 125A or 24V - 60A
- High-riser mixing elbow [instead of L-elbow]
- Extension wire harness [3m, 5m, 10m]
- Hot water kit with cocks
- Second station harness and panel
- C35-panel
- Oil pressure sensor for C35-panel
- Extension saildrive leg [75 mm]
- Propeller cone nut kit SD60
- NMEA 2000 convertor for Engine monitory system
- Emergency stop switch

NOTE: All data subject to change without notice. Text and illustrations are not binding.