

6AYAM-ET

Rating	HP	kW	RPM	Rated Fuel Consumption
Continuous <i>Continuous Duty Unlimited Hours</i>	744	555	1900	39.4 GAL/HR (149 L/HR)

No. of Cylinders	6 in-line
Bore x Stroke	155 x 180
Displacement	20.379 L
Aspiration	Turbocharger + Intercooler
Starting System	Electric Motor Starting (24V 7.0kW)
Cooling System	Keel Cooled (Heat Exchanger Optional)
Size of Flywheel Housing & Flywheel	SAE #0 and 18 in.
Dry Weight	5214 lb (2365 kg)
Dimensions	78.7 x 51.4 x 56.3 in (2000 x 1305 x 1431 mm)
Emissions Certifications	Class Certifications
EPA Tier 3 IMO Tier II	All major Classifications

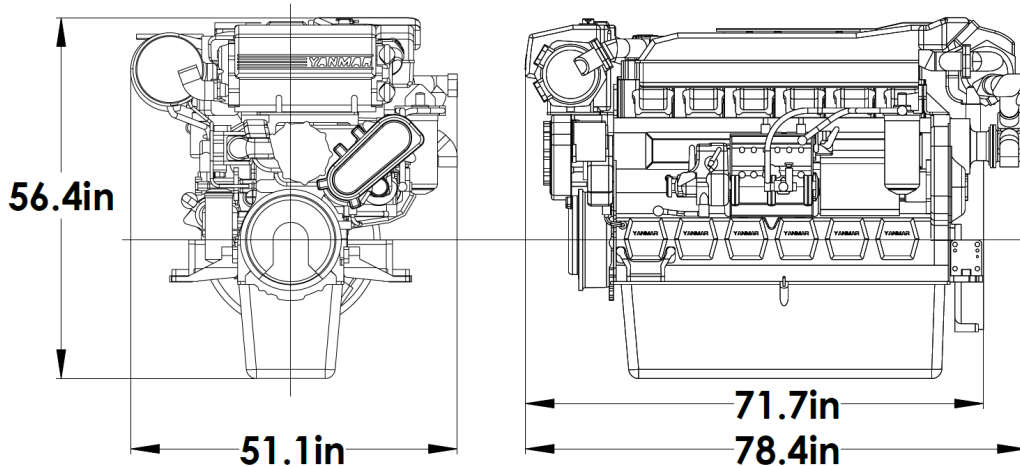

Engine Design FeatureC

- Reliable, marine purpose built engine
- Long stroke, high torque at low RPM
- Forged crank and piston rods
- Gray cast iron pistons, heads and block
- "Silicard" ceramic embedded grey cast iron wet liner and piston rings

Complete Engine and Gearbox Package Benefits

- YXH-240(L) gearbox designed to specifically match engine
- Engine and gearbox load tested as a package
- Engine and gearbox assembled with torsional coupling, oil cooler, mounts, cooling pipes and companion flange included
- Torsional Vibration Analysis report provided free of charge

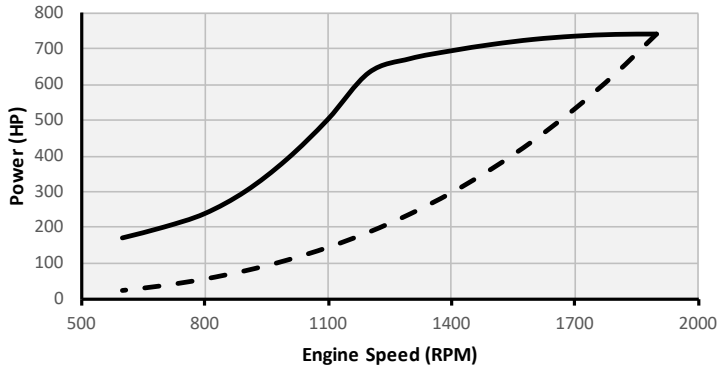
POWER OUTPUT

Propeller power output curves (dotted line) are a 3.0 exponent.

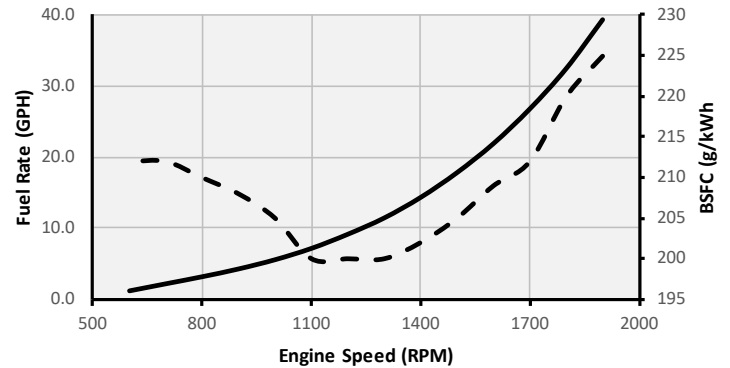
FUEL CONSUMPTION

Brake Specific Fuel Consumption (BSFC) indicated by dotted line.

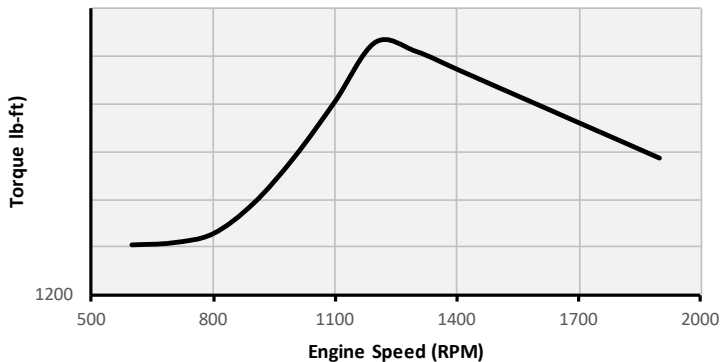
Fuel System Features

- Extremely reliable mechanical design
- Simple design fuel injectors allow for easy self-maintenance
- Replace or simply clean and reuse the injector tips
- Main body of injectors heat treated
- Marine purpose built fuel injection governor / pump
- 5/8" fuel line attachment threads

Cooling System Features

- Keel cooling standard; dual circuit with dual grey cast iron centrifugal pumps
- Heat exchanger option with rubber impeller sea water pump
- Engine oil cooler features stainless and cast iron design

Oil Lubrication System

- 500 hour oil service interval
- Standard oil pan: approximate 30 gallon capacity
- Shallow oil pan: approximate 20 gallon capacity
- Standard dual spin on oil filter assembly with separate by-pass oil filter

Monitoring

- Engine mounted, liquid-filled analog gauges each hard piped to measurement point
- Analog gauges at helm panel with key start / stop